

# Renewable Energy Sources

## Introduction

Past studies and evidence suggest that every year about 28 to 30 million tons (25.4 to 27.2 million metric tons) of carbon go into the formation of new fossil sediments and about 6 to 8 billion tons (5.4 to 7.2 billion metric tons) of carbon are being consumed per year. The rate of consumption is over 200 times the rate of deposition. Because of this, we say that fossil fuels are limited and nonrenewable.

All the things we use everyday to meet our needs and wants are provided through the use of natural resources. Natural resources are either **renewable** or **nonrenewable**. Renewable resources are materials that can be replaced through natural and/or human processes. Nonrenewable resources exist in fixed amounts within the earth and once they're used up, they're gone forever or it takes the earth an extreme amount of time to make them.

**Energy**, derived from natural resources, lights, heats, and cools our homes, offices and factories. It powers the machines of industry and transportation. The clothing we wear, the food we eat, the buildings in which we live and work, and even the systems we use to communicate—all are dependent on energy.

For generations, our society has been enjoying the benefits of plentiful, inexpensive, and easily available energy—fossil fuels. But these fuels, such as coal, oil and natural gas, are finite. As supplies have decreased and become more expensive to extract, the search has intensified for alternative energy sources—sources of energy other than fossil fuels.

The most obvious and virtually limitless energy source is the natural fusion reactor which Earth revolves around in space—the **sun**. In terms of humankind's residence on Earth, the sun is an object that will last forever, continuously radiating energy that makes life on our planet possible. Although Earth intercepts only a small fraction of the total energy emitted by the sun, the amount received is thousands of times the present energy requirement of the world's human population.

Other renewable energy sources include **wind** energy, **hydroelectric** energy, **biomass** energy, **geothermal** energy, and various forms of energy derived from the **ocean**. New ways and ideas to harness or use these renewable energy sources are continually being researched and developed.

## How is the sun an energy source?

The surface of the sun, which radiates energy in the form of heat and light, is called the **photosphere**. The sun's interior is composed of dense gases (70 percent hydrogen and 28 percent helium) and high temperatures (27 mil-

lion degrees Fahrenheit/15 million degrees Celsius). The heat and light energy is produced through a **thermonuclear** reaction (fusion) in which hydrogen atoms are fused together to form helium.

Of the sun's energy that reaches Earth's atmosphere, 30 percent is reflected back into outer space, 47 percent is absorbed by Earth's surface and converted into heat energy, 23 percent drives the hydrological (water) cycle, less than one percent creates winds and ocean currents, and only 0.03 percent is captured by plants and used in photosynthesis. The 0.03 percent of the sun's energy captured by plants provides all the world's food energy and produced the stored fossil fuel energy (coal, oil, natural gas). Thus, the sun is the primary source of all energy on Earth.

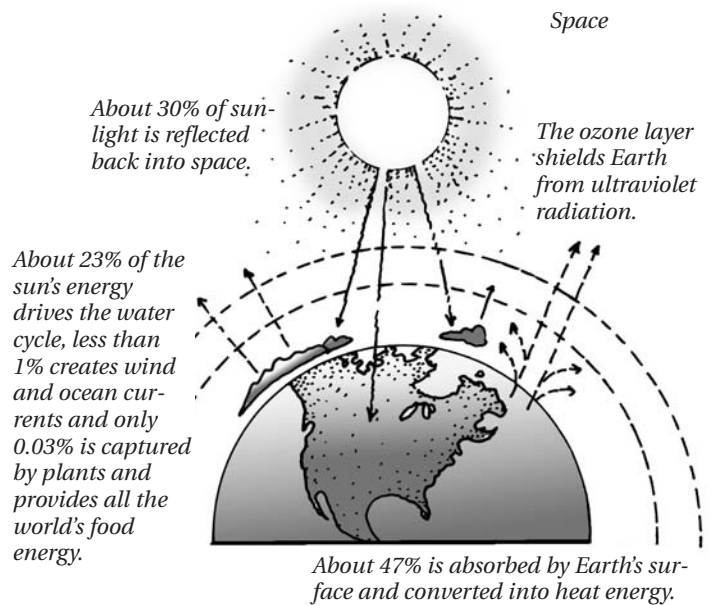

*The sun is the primary source of all energy on Earth.*

The sun's position in the sky has a major effect on the solar energy received by Earth. In order to collect and use solar energy efficiently, one must be knowledgeable of the sun's movements, both daily and seasonally.

## Is there a difference between heat and temperature?

To understand solar energy, one must understand the principles of heat, temperature, and heat flow since solar energy technologies are based on these principles.

Heat and temperature are different, but often incorrectly interchanged. Heat is an indication of how much energy an object contains; whereas temperature is the hotness of an object. The heat energy contained by an object is influenced by many factors; including temperature, the

composition of the object, and the size of the object. For example, if a nine-inch (23 cm) diameter pie tin and a five-inch (12.5 cm) diameter pie tin were filled with dirt and heated in an oven for several hours, each would have the same temperature, but the nine-inch (23 cm) diameter pie tin would contain more heat energy because of its larger size.

Heat energy also flows from warm objects to cold objects because of the temperature difference. The heat will continue to flow from the warm object to the cold object until the temperatures are equal. There are three natural means by which heat flows: **conduction**, **convection** and **radiation**. Conduction is the transfer of heat through a solid. Convection is the transfer of heat by movement of a liquid or a gas. Radiation is the transfer of heat in waves through the air.

Temperature difference causes heat to flow, but how fast the heat flows is determined by the thermal resistance of the object. **Thermal resistance** is influenced by temperature difference, the composition of the object, its state of matter (gas, solid, liquid) and the area of the heat flow path.

### What is solar radiation?

**Solar radiation** is a form of electromagnetic radiation, such as x-rays, light waves, microwaves, television waves and radio waves. However, solar radiation differs from heat flow radiation. This difference is important to solar energy technologies.

First, color is an important factor in solar radiation, but is not in radiation heat flow. Black or dark-colored objects absorb solar radiation and become hotter, while white or light-colored objects reflect solar radiation. Color has no effect on radiation heat flow. Light- and dark-colored objects will absorb the same amount of heat energy from radiation heat flow.

The second most important difference is that solar radiation passes through transparent materials (glass, plastics), whereas radiation heat flow cannot. Thus, transparent materials trap heat energy.

### How is the sun's energy harnessed?

Three primary processes exist by which solar energy can be put to practical use: **photochemical**, **photoelectrical**, and **photothermal**. The photochemical process, called photosynthesis, uses solar energy to unite carbon dioxide, water, and nutrients from the soil to create carbohydrates (chemical potential energy) and oxygen. The coal, oil and natural gas we use today probably resulted from photosynthesis that took place eons ago.

In the photothermal process, light energy (shortwave radiation) is transformed into heat energy (longwave radiation). As light energy strikes an object, it is either absorbed, reflected or transformed into heat energy. The heat energy is then either radiated away from the object,

carried off by air or water (convection), or conducted to surrounding objects.

Photothermal technologies include: **passive and active solar energy systems**, **power towers** and **Ocean Thermal Energy Conversion (OTEC)** systems.

The photoelectrical process converts light energy into electrical energy. It involves the use of photons (light energy) to excite the outer (valence) electrons of atoms, causing the electrons to move, producing an electrical current. Photoelectric technologies include photovoltaics.

### What is a power tower?

Power towers produce electrical energy from the absorbed heat energy of the sun. In their design, a **central receiver** (boiler) is placed at the top of a tall **tower** located in the center of a field of sun-tracking mirrors (**heliostats**). The solar energy reflected from the mirrors is absorbed by the receiver and used to heat a liquid or gas. The high-temperature, high-pressure vapor turns a turbine which turns a generator to produce electricity. It can also be used to deliver heat energy to a thermal-storage unit for deferred operation. The mirror field for a 100 megawatt facility consists of about 20,000 heliostats, requiring roughly 2.2 square miles (3.5 square kilometers). The tower for a power plant of this size is 284 yards (260 meters) high. The solar energy concentrated upon the central receiver is over 1,000 times as great as the normal solar radiation and will raise the temperature of the receiver 1475°F to 2200°F (800°C to 1200°C). Power tower feasibility is controlled by the sun's availability and space, thus power towers are located in sunny, sparsely populated areas like the Southwestern United States.

### What are photovoltaics?

**Photovoltaic** comes from the words "photo" meaning light and "volt" a measurement of electricity. Photovoltaic cells are sometimes called PV or **solar cells**. In the photovoltaic process, light is converted directly into electricity.

Light is composed of tiny bundles of energy called **photons**. When photons reach the earth they interact with the atoms of solids, liquids, and gases. An atom consists of a nucleus surrounded by electrons. When incoming photons strike an atom, energy is converted. In some atoms the added energy knocks the atom's outer electron(s) off. Electrons freed in this manner are known as **conduction electrons** because they form an electric current. Photovoltaic solar cells are designed to take advantage of this phenomenon.

**Silicon** is used to form very thin wafers to make photovoltaic solar cells because its electrons are easily displaced by absorbed photons. In some wafers a small amount of phosphorous is added giving the wafers of silicon an excess of free electrons so it will have a negative character. This wafer is called the **n-layer**. In some wafers

a small amount of boron is added giving the wafers of silicon a positive character because it attracts electrons. This layer is called the **p-layer**. Keep in mind that the n-layer has a negative character, not a negative charge; and the p-layer has a positive character, not a positive charge.

When the two wafers are placed together the free electrons from the n-layer flow into the p-layer for a split second, then form a barrier to prevent more electrons from moving from one layer to the other. This contact point and barrier is called the **p-n junction**.

After the layers are joined the p-layer section of the junction has a negative charge and the n-layer section of the junction has a positive charge. An electric field is produced between the p-layer and the n-layer at the p-n junction because of the imbalance in the charge of the two layers.

Place the PV cell in the sun and photons of light energy strike the electrons in the p-n junction, energizing them and knocking them free of their atoms. These electrons are attracted to the positive charge in the n-layer and repelled by the negative charge in the p-layer.

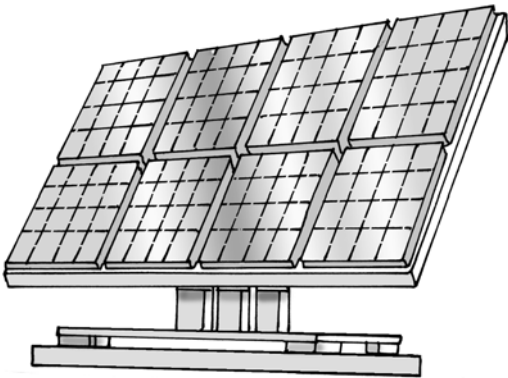

*Photovoltaic Solar Cell*

If you attach a wire between the p-layer and the n-layer, the free electrons are pushed into the n-layer and repel each other. The wire provides a path for the repelled electrons to get away. This flow of electrons is an electric current.

For many years, PV cells have been used for specialty applications such as powering space craft, remote weather stations, and consumer products such as watches and calculators. But today, PV cells have become a common power source for a wide variety of telecommunications equipment, including cellular phone towers, radio-controlled valves used on oil and gas pipelines, and in weather stations. Solar-power watches have batteries that are continually recharged by small PV cells. This same technology is used in calculators and toys. In remote areas, excess electricity can be stored in batteries for use when the sun isn't shining.

## What is wood energy?

**Chemical potential energy** is produced by plants through **photosynthesis** and is stored as **biomass**. The chemical potential energy of biomass is released when the plants decay or are burned.

Wood is one of the most abundant and useful forms of biomass on this planet. Even though trees take 50 to 100 years to reach maturity, we can use this valuable resource forever if we grow and harvest trees with care and planning. The most ambitious plan for the use of wood fuel is the "energy plantation." These are large tracts of land devoted to the production of trees for use in nearby electrical generating plants. It is estimated that a 1,000 megawatt plant would require between 200 and 600 square miles of woodland in order to have a sufficient supply of wood fuel.

However, there are problems with large-scale use of wood. Unless the harvesting of trees is done carefully and properly, the soil can become seriously depleted of nutrients and eroded. Also, there are simply too many of us and we want far more energy than our grandparents or great-grandparents did: so wood cannot fully satisfy our energy needs. There are also air pollution problems with burning wood in heavily populated areas.

## What are biofuels?

**Biofuels** are derived from plants, which capture the sun's energy and convert it to biomass (chemical potential energy) through photosynthesis. Biofuels are distinguished from fossil fuels, which are also of biological origin, but are nonrenewable. Biomass, in the process of being eaten, burned or decayed, transfers its energy to the rest of the living world. There are many proposals for biomass energy plantations. One idea calls for growing sea kelp in the offshore waters of California and Peru to produce 1.8 billion tons of dry marine algae per year. This biomass would then be converted to methane.

Some farmers are already growing crops to convert into ethanol. **Ethanol**, a biofuel, is mainly produced from corn. Other plant material, such as sugar cane and rice straw (agricultural waste), have also been used. The advantages of biofuels over other fuel sources are: domestic production would have a favorable economic impact, a more favorable impact on the environment (biomass is low in polluting sulfur), and the energy produced is renewable. There are, however, problems with the energy plantation concept; large land areas would be needed and by centralizing energy production, the energy plantation would require elaborate electricity transmission grids.

## How is refuse an energy source?

One type of biomass that has potential as an energy source is **organic waste** or **refuse** (garbage). Although still considered a problem rather than a resource, there is little

doubt that refuse will be used more and more as raw materials for conversion and recycling. Refuse can also be converted to other useful forms by **composting** (decaying organic materials to produce a soil conditioner and fertilizer) or **anaerobic digestion** (decaying organic material in airtight containers to produce methane, liquid fertilizer, or distilled to produce ethanol). However, we must remember that it takes energy to produce the items that become our refuse. **Conservation**—using less paper, plastics, fabrics, aluminum, etc.—saves more energy than conversion and recycling.

### How is wind an energy source?

Wind is a form of **kinetic energy** created in part by the sun. About two percent of the sun's energy that reaches the earth is converted to wind energy. The atmosphere is heated during the day by the sun and at night it cools by losing its heat to space. Wind is the reaction of the atmosphere to the heating and cooling cycles, as well as the rotation of the earth. Heat causes low pressure areas, and the cool of the night results in high pressure areas. This process creates wind when air flows from high pressure areas into low pressure areas.

Wind energy has been used for hundreds of years. The windmills of Europe and Asia converted the kinetic energy of the wind into **mechanical energy**, turning wheels to grind grain. Today wind-driven generators are used to convert the kinetic energy of wind into **electrical energy**. Wind-driven systems consist of a tower to support the wind generator, devices regulating generator voltage, propeller and hub system, tail vane, a storage system to store electricity for use during windless days, and a converter which converts the stored **direct current (DC)** into **alternating current (AC)**.

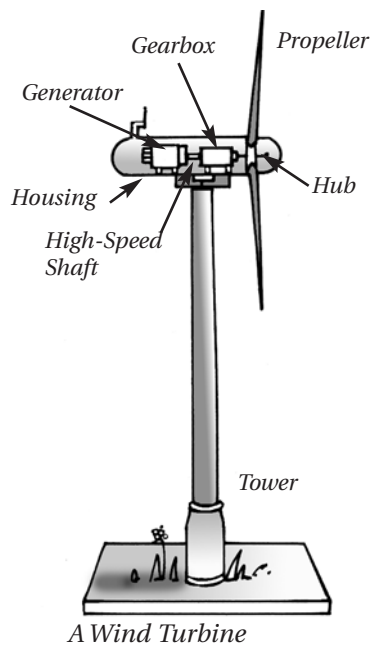

A Wind Turbine

Wind energy accounts for 6 percent of renewable electricity generation. The U.S. wind energy industry achieved unprecedented success in the first year of the new century, installing nearly 1700 megawatts or \$1.7 billion worth of new generating capacity. Due to continuing research and better placement of turbines, wind power has become much more reliable.

Virtually all regions of Canada have areas with good wind resources. Oceans and large lakes, open prairie, and cer-

tain hill or mountain areas often have good winds, and these areas are where Canada's current wind generation facilities are located. There are commercial wind turbines in five provinces and the Yukon, with plans for further installations in almost all the rest of the provinces.

Natural Resources Canada estimates that Canada has almost 30,000 megawatts of developable wind resource. This compares to the current installed base of 200 megawatts, and would be enough to supply 15 percent of Canada's electricity supply.

The wind energy future looks bright and there is a growing interest in wind power within the North American electric industry. Wind power is a clean and renewable energy source, it produces no pollution and it doesn't harm our earth. Also important is the fact that the price of wind power is not affected by fuel price increases or supply disruptions—it is a domestic, renewable energy source. The land used for wind turbines can still be used for other purposes such as grazing and farmland.

### What is hydropower?

Hydropower is a form of solar energy. The sun's energy drives the **hydrologic cycle** by evaporating water from lakes and oceans and by heating air. The hot air then rises over the water carrying moisture to the land. The cycle continues when the water falls as precipitation and flows back to lakes and oceans.

The potential energy of water located at elevations above sea level is one of the "purest" forms of energy available. It can provide energy without producing pollution. It is relatively easy to control and can be converted to electricity with an efficiency of 75–85 percent. As a result, large and small rivers around the world, with the appropriate topography, have been dammed and waterwheels and water turbines installed to capture the kinetic energy of the falling or flowing water.

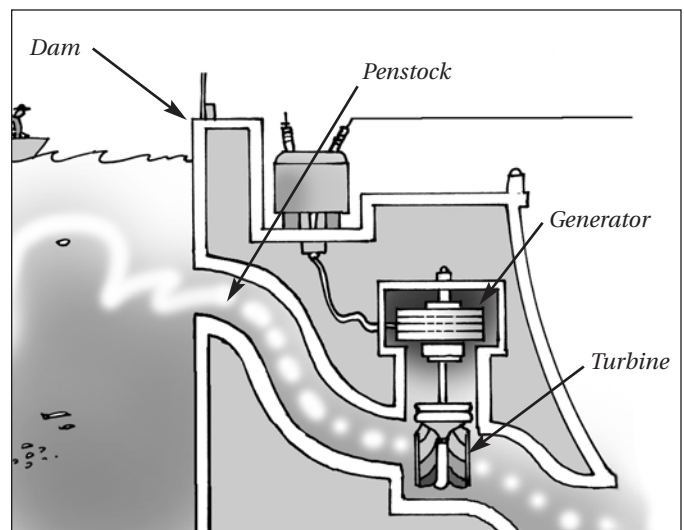

Hydroelectric Dam

**Hydroelectric** installations require the construction of dams to increase the reliability of the energy available from a stream. The dam also regulates the flow of water and creates water pressure at the bottom of the dam. The water pressure is proportional to the depth of the reservoir created by the dam. The greater the water pressure, the greater the power.

Water from the reservoir flows through the dam in pipes called **penstocks** to the **powerhouse**. In the powerhouse the water pressure is applied to a **turbine** which spins a **generator** to produce electricity. After the water has moved through the turbine, it is released into the river below the dam.

Hydroelectric power is cost-effective and proven. However, there are drawbacks. The damming of a river or stream has a critical and sometimes irreversible impact on the long-term ecological balance of that river or stream. Dams also encourage an accumulation of silt and can be a hazard in earthquake zones. However, dams create a better environment for some animals and plants, provide new recreational areas, and can control natural disasters such as floods and erosion.

Hydroelectric generation accounts for about 24 percent of all electric generation worldwide, and about 8 percent in the U.S. Current hydroelectric generation in the United States is at about 20 percent of its potential. However, most remaining hydroelectric generating facilities would be in the form of small dams (10 – 30 megawatts).

The flow of water accounts for most of the electric power Canadians use—61 percent. Canada's land features are well suited for hydropower. A good example is the Canadian Shield, an area of rugged terrain and large river systems that stretches from Hudson Bay to Labrador and from the Great Lakes to the Arctic. More than one-third of our hydroelectric capacity is located on rivers that are situated in or flow into this region.

Hydroelectricity provides most of the power used in Quebec, British Columbia, Manitoba, Newfoundland and Labrador, and the Yukon. The province of Quebec is the country's largest producer of hydroelectricity, with 93 percent of its electricity produced by hydroelectric facilities. Almost half of our country's hydroelectric capacity is found in this province.

### How are ocean tides an energy source?

The **potential energy of gravity**—caused by the relationship between the earth, moon, and sun—and the kinetic energy of Earth's rotation creates tides and the kinetic energy associated with their rising and falling. The key to the usefulness of **tidal energy** is the height difference between high and low tide.

In order to obtain energy from tides, a dam must be constructed across a coastal inlet. The dam allows water to flow inward at high tide, trapping the water. At low tide

the water is allowed to flow back through the dam in a penstock. The flowing water turns a turbine and generator, producing electricity.

There are only a few locations in North America that are suitable for tidal energy development.

### How are ocean waves an energy source?

The **kinetic energy of waves** is derived from the interactions of winds and ocean currents. Methods for harnessing the kinetic energy of waves are new and untested. Several different devices have been successful on a small-scale operation. All of them operated by using the natural up-and-down motion of waves. For example, the Madsuda buoy consists of an upturned canister with two holes in the top portion of the container floating in the water. As the waves rise and fall inside it, air is forced in and out by air pressure. The stream of air drives an air turbine, which, in turn, drives a generator producing electricity.

Waves, like wind, are unpredictable. Presently, wave energy is not economically feasible.

### What is geothermal energy?

**Geothermal energy**, heat from within the earth, is the result of radioactive decay, chemical reactions, friction from the movement of crustal plates, and heat present from the earth's formation.

There are three basic forms of geothermal energy: **hydrothermal**, **geopressurized**, and **hot dry rock**. Hydrothermal systems are composed of hot water and steam trapped in porous or fractured rock near the earth's surface. Geopressurized reservoirs contain a mixture of hot water and methane gas trapped in sedimentary rock far beneath the earth's surface. Hot dry rock formations contain abnormally hot rock and little water.

Most of the recoverable United States geothermal reserves are located within the Western states; Alaska, California, Idaho, Montana, Nevada, New Mexico, Oregon, Utah, and Washington.

All geothermal energy sources can be used in industrial processes and space heating, but only hydrothermal resources can be used in electrical generation.

Hydrothermal resources use steam directly to turn a turbine and generator to produce electricity. In the process, steam is condensed to water and returned to the earth.

Direct application of geothermal energy to heat buildings can be found in Reykjavik, Iceland; Klamath Falls, Oregon; and Boise, Idaho. Electricity is produced by geothermal energy in California and Utah in the U.S.

Environmental and maintenance problems arise when the hot geothermal water, saturated with soluble minerals, cools and deposits the minerals in pipes and equipment. Geothermal energy, because of its localization, cannot satisfy North America's overall energy needs.